



WALL MOUNTED ENERGY RECOVERY VENTILATOR

Brise - Wellness begins with a gentle breeze
PM 2.5 Sensor



99% air purification



Indoor&outdoor air filtration



High efficiency heat and humidity recovery



Quiet operation



App control



High efficiency DC fans



Remote control



Low energy consumption



Easy installation



Group control



Available on App Store and Google Play.
Work with Alexa and Google Assistant.

*Exclude disposable filter

Accessories

Wifi Module



Humidity Sensor



PM 2.5 Sensor



MERV10+HEPA Filter



CO2 Sensor (OPTIONAL)



Technical Parameters

	Unit	BEAIR-WM100-PM2.5							
Speed		1	2	3	4	5	6	7	8
Airflow	CFM	30	38	46	55	63	71	79	89
Power Supply		120V, 60Hz, 1Ph							
Max. unit power	W	12.6	16.9	18.1	20.9	25.2	29.2	34.2	43.8
Max. unit current	A	0.16	0.18	0.19	0.21	0.24	0.27	0.31	0.37
Sound pressure level at 1.5m distance	dB(A)	22.6	25.1	27.7	29.7	31.7	33.1	35.1	37.9
Operating Range		-15 °C ~ +40 °C							
Casing material		ABS							
Motor type		DC Type							
Filtration efficiency		99% HEPA							
Filtration mode		Pure High, Pure Medium, Pure Low							
Temperature efficiency		82%							
Enthalpy heating efficiency		58%							
Enthalpy cooling efficiency		52%							
Control		Touch Screen Panel / Remote control							
Air quality display		PM 2.5, Temperature and Relative Humidity							
Operational mode		Manual / Auto / Timer / Sleep							
Suitable room size	m2 / sqft	20 - 45 / 215 - 485							
Dimension	mm / in	450 x 155 x 660 / 17-3/4 x 6-1/8 x 26							
Weight	kg / lb	10 / 22							

Dimensions (in)

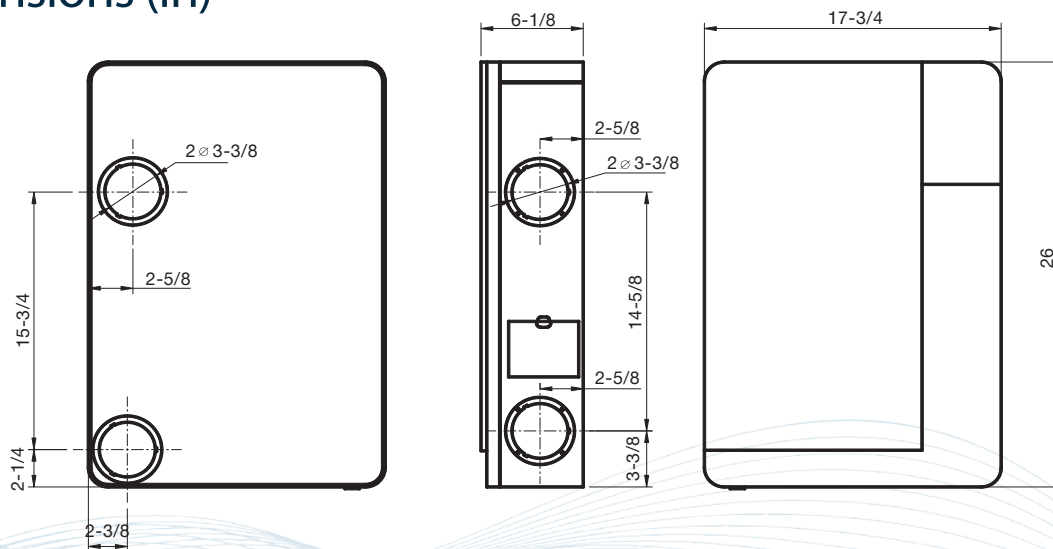

Additional Information

The package has included all the accessories needed for the installation. user don't need to prepare extra accessories and save costs.

The primary filter, MERV10, the HEPA H10 filter, and activated carbon filters are included at the supply air side.